

D15 Backup Switch Specifications PN:8229



Product Summary

The D15 Backup Switch allows for easy switching from wireless to wired systems with the toggle of a single switch. This ensures you have the least down time with your customer and maximizing the selling potential of your business.

D15 Backup Switch Diagram

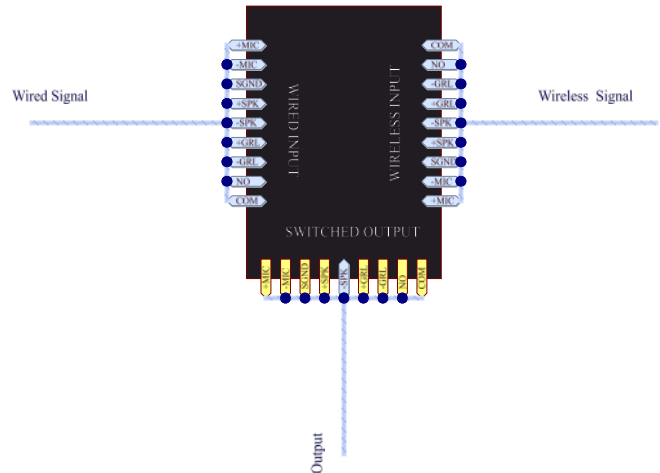

Features

- Terminal blocks for easy connections
- Signal labels for easy installation
- Easy wall mounting holes
- Single action switching from wireless to wired
- Flame Retardant ABS UL94V-0

Product Specifications

- 5.00 x 3.50 x 1.5 in/ 127.00 x 88.90 x 38.10 mm
- 0.45 lbs
- Single Switch Bar
- Terminal Blocks

Warranty

- 1 year